



Product Technical Specification
AccuSlit B-10
Slitting Machine with Taping

V.PT722.0.1





AccuSlit B-10 Slitting With Taping

AccuSlit B-10 FLOOR DIMENSION

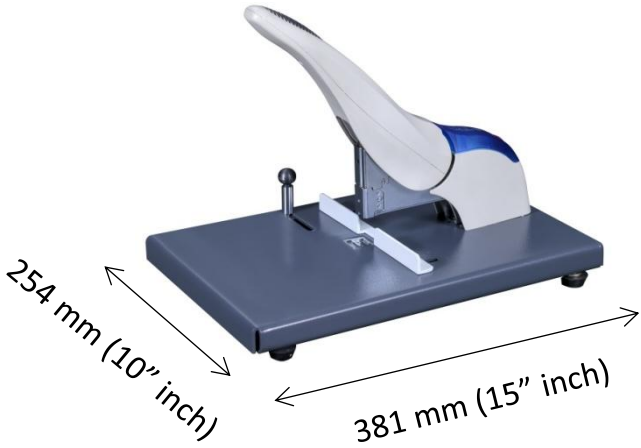
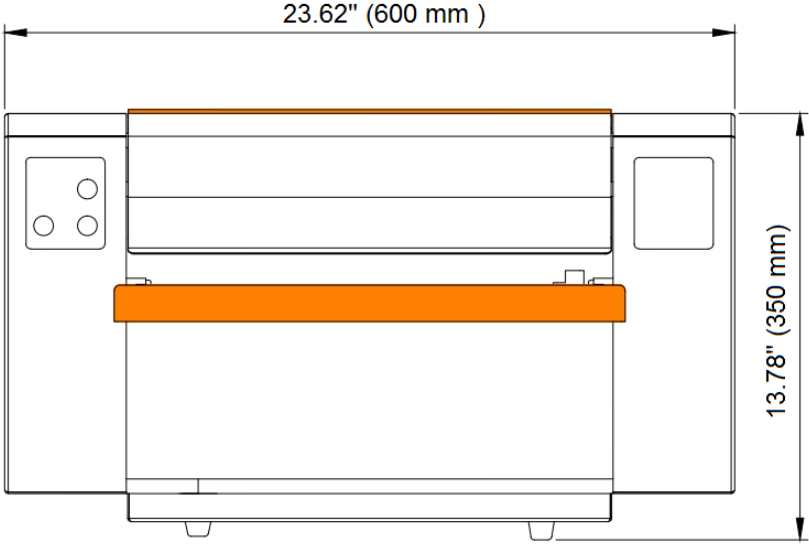
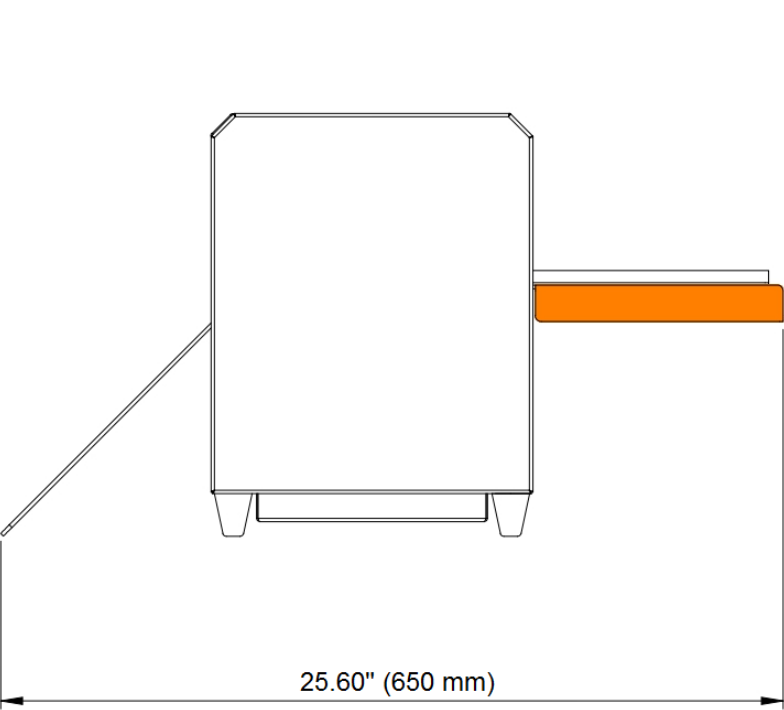

TECHNICAL SPECIFICATION

MACHINE DIMENSION	650 x 600 x 350 (mm)
POWER SUPPLY	220V AC (50 Hz)
POWER CONSUMPTION	250 WATTS
SPEED	350 SHEETS / HOUR
PAPER WIDTH	125 mm x 255 mm 5" x 10" (INCH)
PAPER LENGTH	125 mm x 255 mm 5" x 10" (INCH)
PAPER FEED	MANUAL
PAPER THICKNESS	150 GSM – 200 GSM

FEATURES

❖ Manual Feeding

Manual Feeding: For enhanced precision and accuracy in feeding, the Roller is specifically programmed to prevent overlapping and maintain a consistent distance between two sheets.

❖ One Slitting Device with Taping

The Slitting and Tapping Device is fixed, but we can modify the Paper guide to align with the Slitting area on the Print.

FEATURES

❖ Tape

- The specially designed transparent adhesive tape ensures secure joint adherence, resulting in precise binding.
- The tape material consists of Polyester with a thickness of 25 microns.

❖ Auto Cut (Sheet Separator)

Built in automatic cutting system for cutting tapped sheets

SPINE & STAPLING AREA

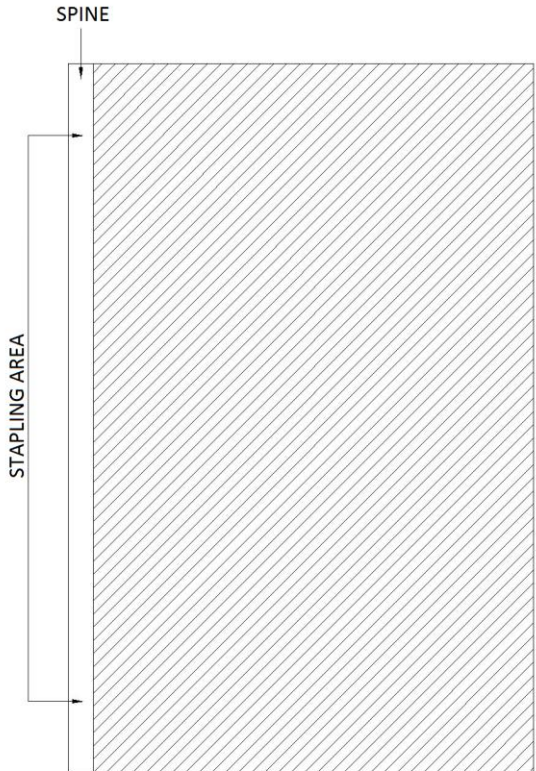
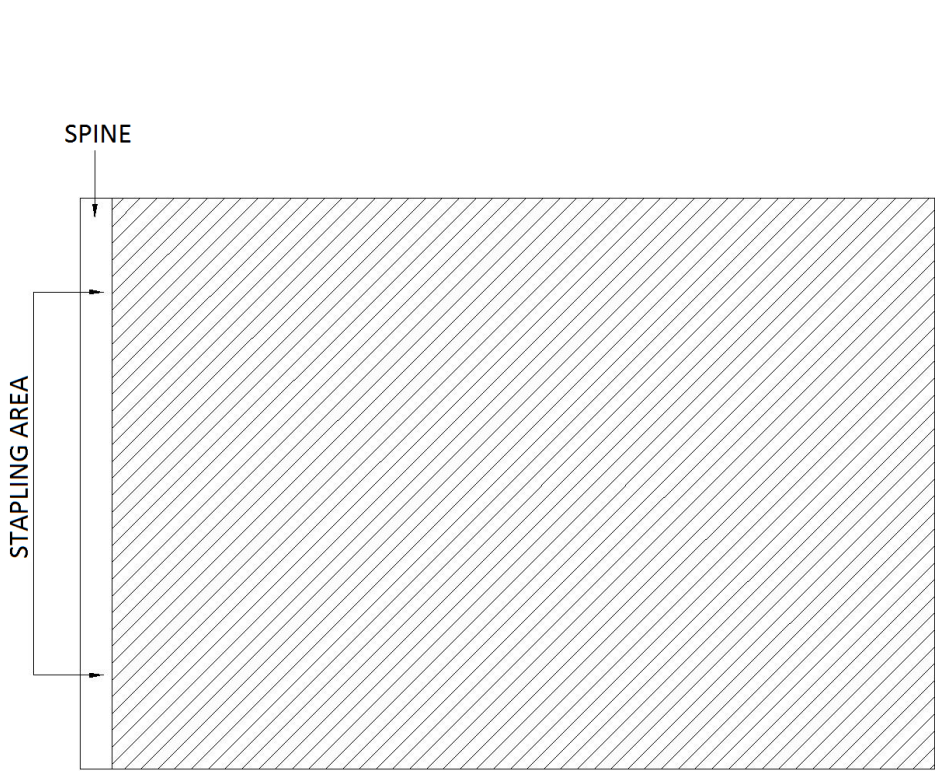



pinnacletechnocrats.com



sales@pinnacletechnocrats.com

