



Product Technical Specification

THERMAL LAMINATION LP13 FL
Foiling & Lamination Machine

V.PT722.0.1





THERMAL LAMINATION LP13 FL

THERMAL LAMINATION LP13 FL FLOOR DIMENSION

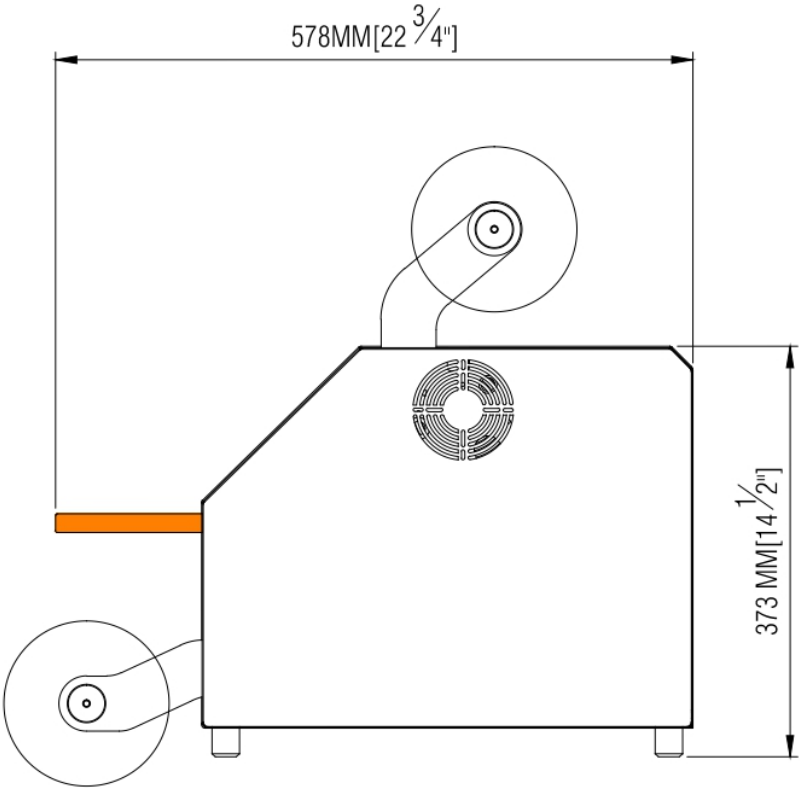
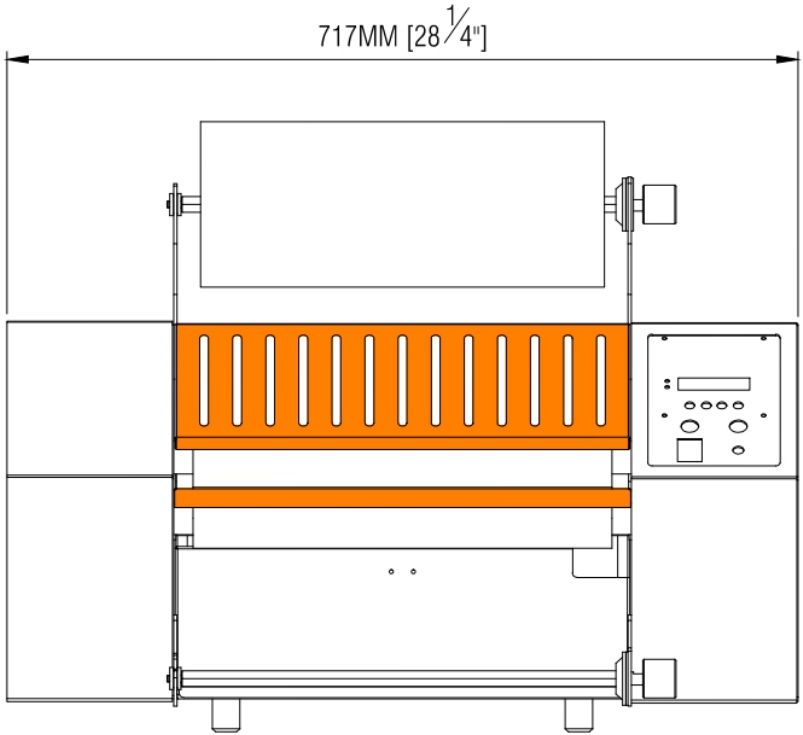

THERMAL LAMINATION LP13 FL



TECHNICAL SPECIFICATION



MACHINE DIMENSION	717 x 578 x 373 (mm)
POWER SUPPLY	220V AC (50 Hz)
POWER CONSUMPTION	2000 WATTS
LAMINATION SPEED	UPTO 5 MTR / MIN
FOILING AREA & LAMINATING	305 mm 12" (INCH)
PAPER PATH	360 mm 14" (INCH)



Thermal LP13 FL is Pinnacle's latest model developed, especially to give an exotic and enhanced finishing to the media / prints.

As the name implies, Thermal LP13 FL is a compact model, that has two key functions of Prints Foiling the embossed UV area and Laminating for Single side or Double side option.

FEATURES



- User friendly Keypad Display to operate various functions.
- Sensor has been provided to maintain Accurate Temperature.
- Easily controlled speed for varied papers and lamination films, speed is up to 5mtrs/min.
- Accurate Combination of Foiling and Laminating processes.
- Compact design.







pinnacletechnocrats.com



sales@pinnacletechnocrats.com

