



Product Technical Specification

**THERMAL LAMINATION LP13 SLa**  
**Slitting with Thermal Lamination**



## THERMAL LAMINATION **LP13 SLa** Auto Feeding & Manual Cut

# THERMAL LAMINATION LP13 SLa FLOOR DIMENSION

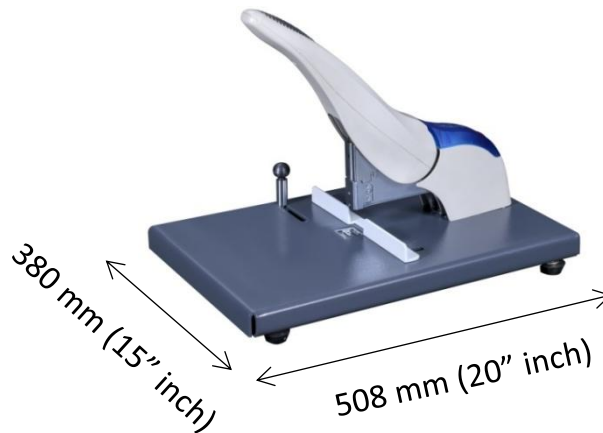
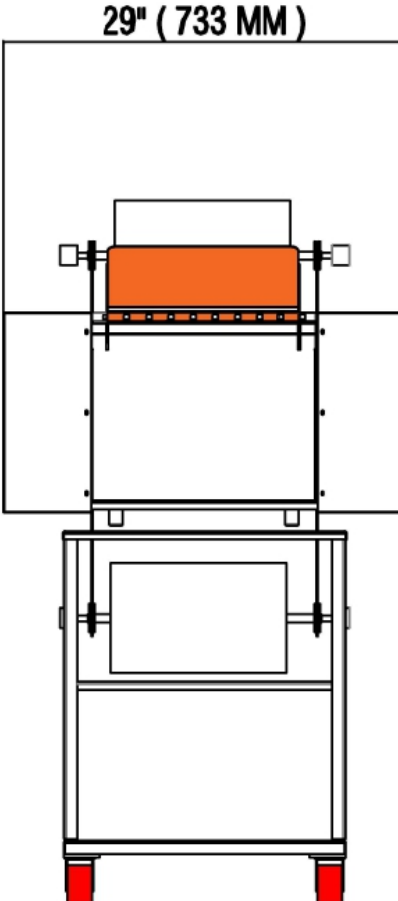
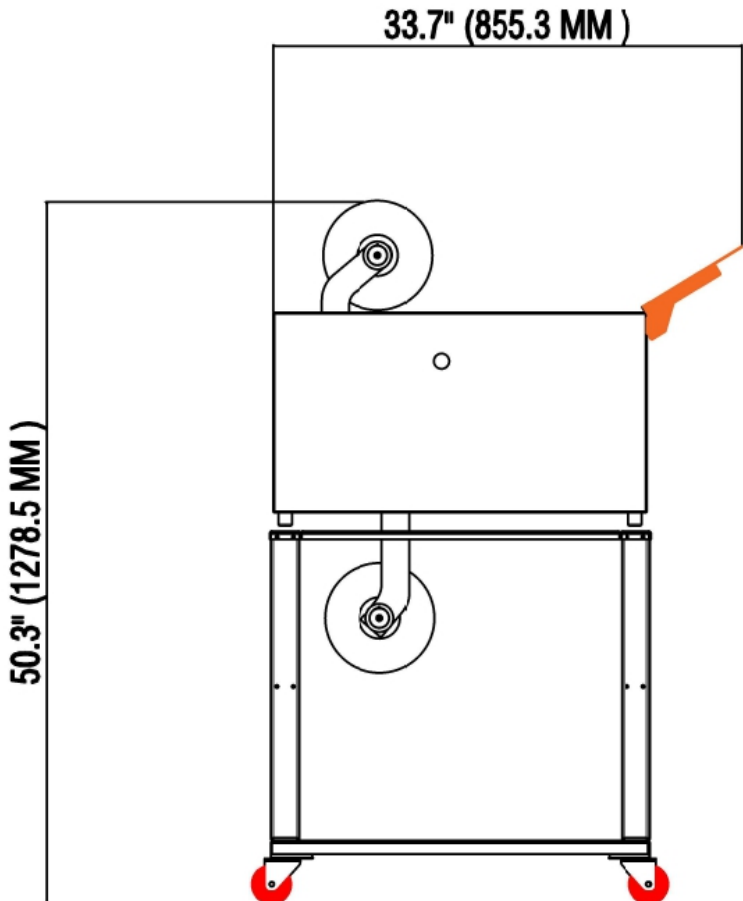

# TECHNICAL SPECIFICATION

MACHINE DIMENSION 13 (inch)	855 x 733 x 1279 (mm)
POWER SUPPLY	220V AC ( 50 Hz )
POWER CONSUMPTION 13 (inch)	1800 WATTS
LAMINATION SPEED	UPTO 5 MTR / MIN
MAX PAPER SIZE	330 mm   13" (INCH)
THICKNESS OF PAPER	170 GSM – 300 GSM

**\* Any type of Media / Paper static charge should be less then 2KW at the time of binding process \***

Thermal Lamination LP 13 SLa is a combination of Slitting & Double Side Lamination to create a Flat Open Photo Book. With Auto feeding system (Friction Feeder) you can use it either for Inline **Slitting** with Double Side Lamination or only for Double side **Lamination** purpose also.

# FEATURES

- User friendly Touch Display to operate various functions.
- Auto Feeder System (Friction Feeder)
- Manual Cut After Lamination.
- High Accuracy Sensor has been provided to maintain Accurate Temperature.
- Easily controlled speed for varied papers and lamination films, speed up to 5 mtr /min.
- 1”(Inch) core for small lamination film roll & 3”(Inch) core for jumbo Film roll.
- Standby mode to save the power consumption on idle condition of the machine.
- Dust cleaning system before slitting process.
- Heavy motors are provided to run the jumbo film roller.

# FEATURES



**Slitting Device**



**Dust Cleaning Roll**

# SPINE & STAPLING AREA

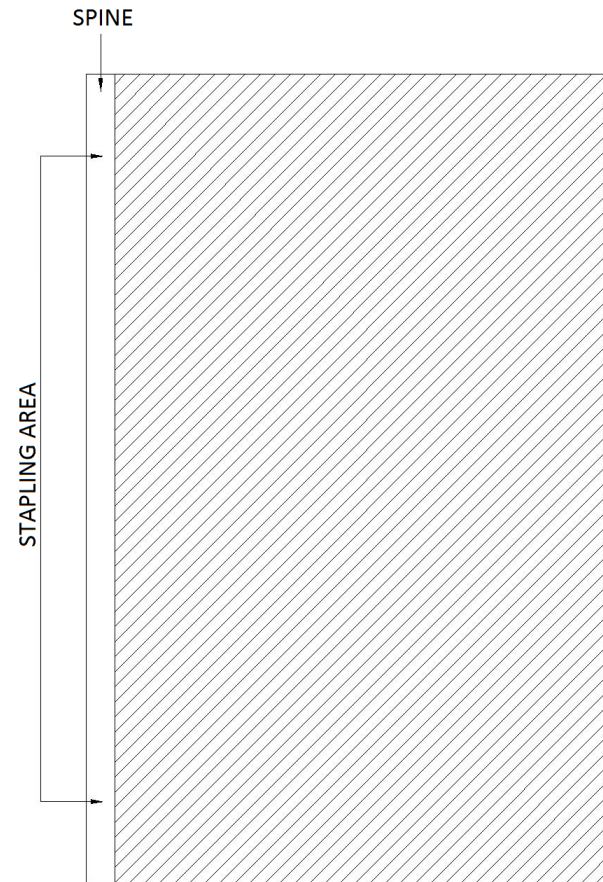

**REQUIRED SPINE DISTANCE MINIMUM 15 MM**

2 UPS PRINT VERTICAL

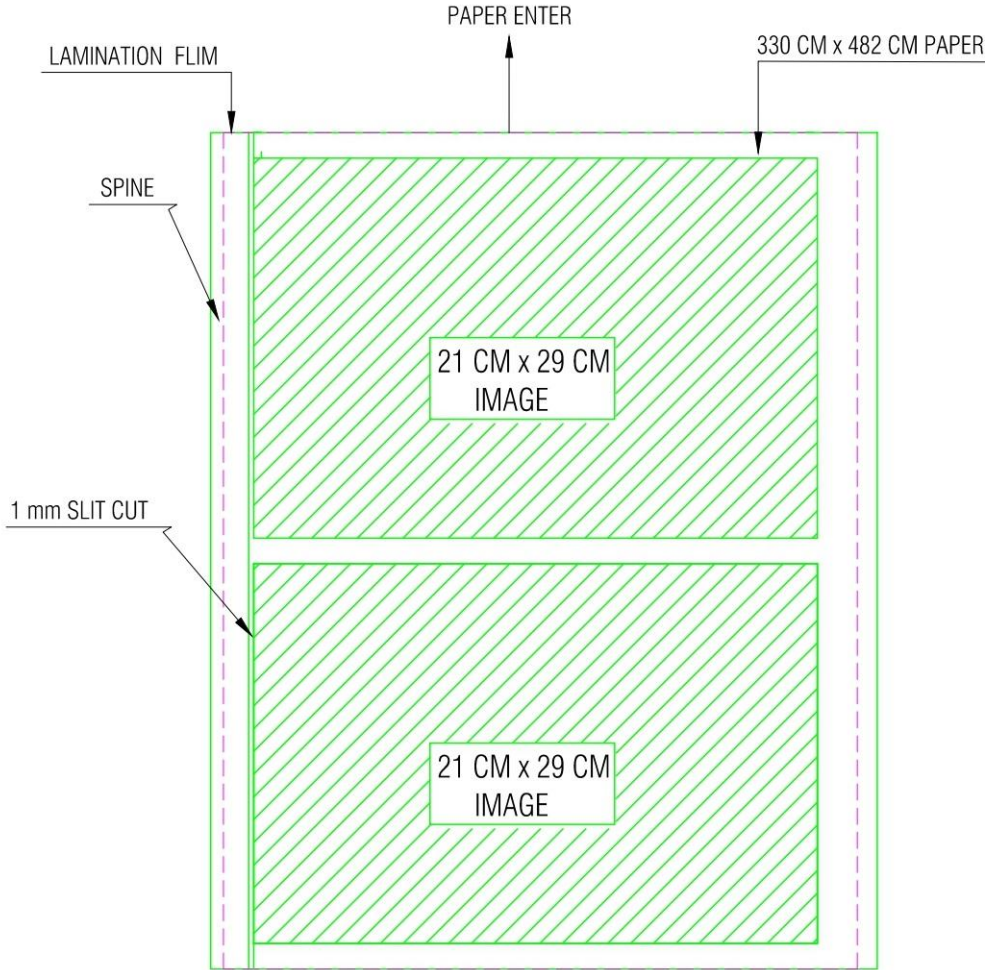

## Different Possible Size & More :-

- 1.) 30cm x 30cm
- 2.) 38cm x 30cm
- 3.) 48cm x 30cm

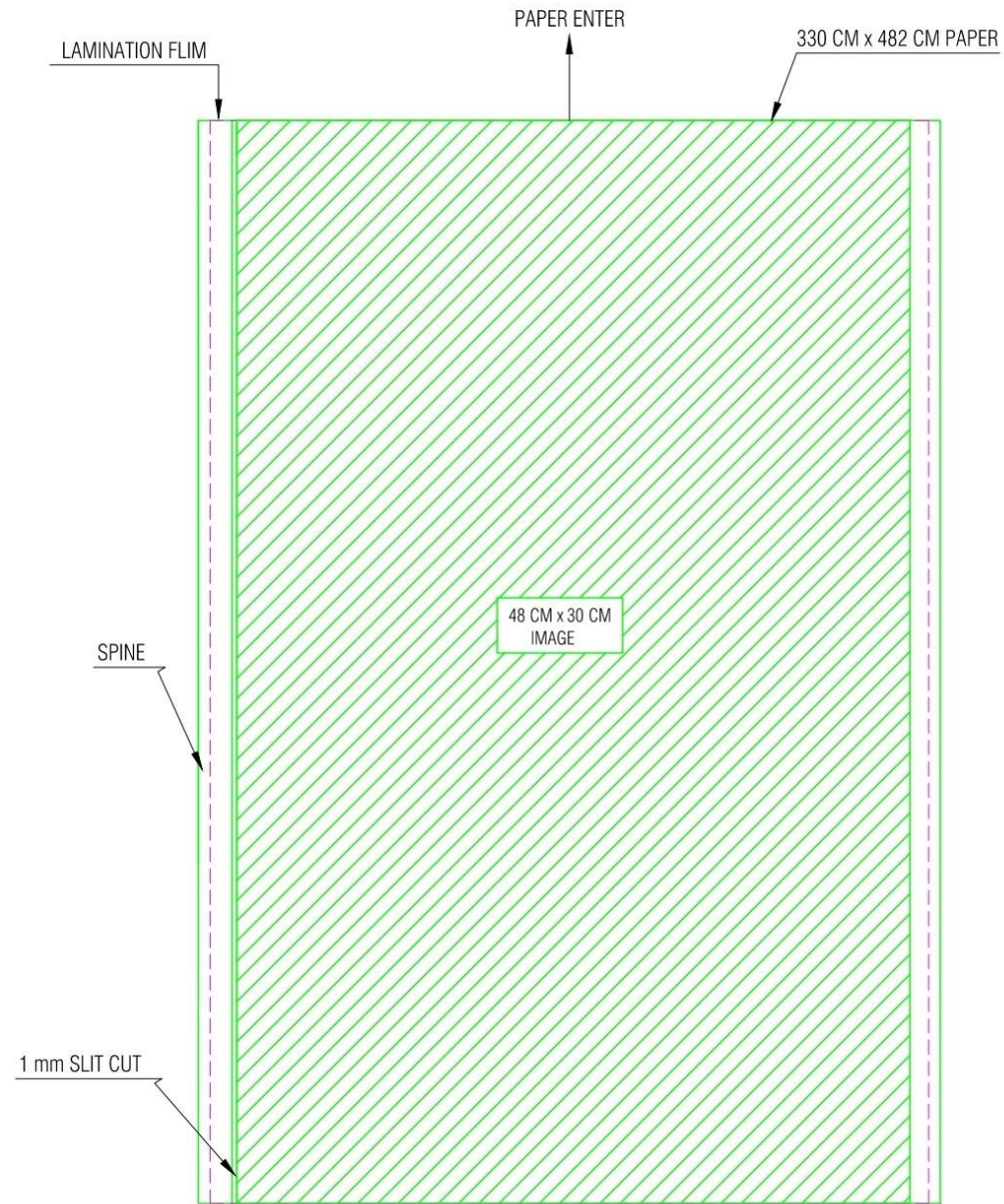

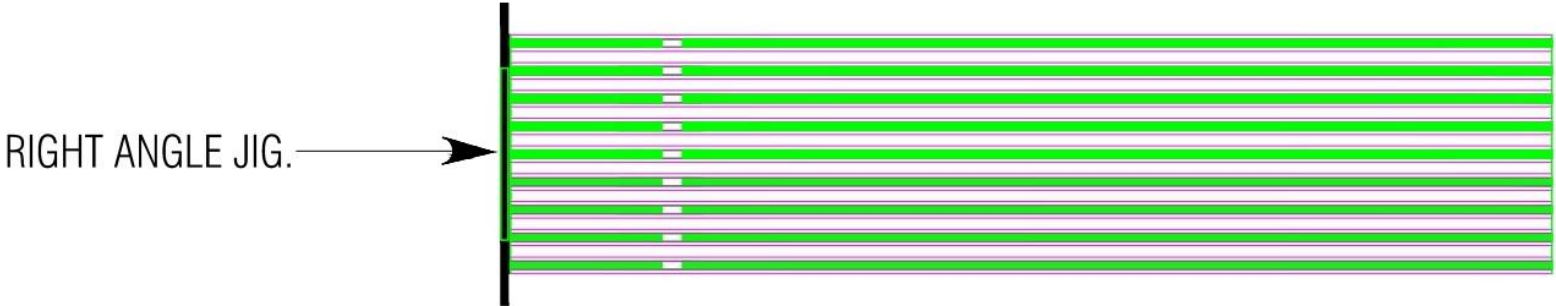
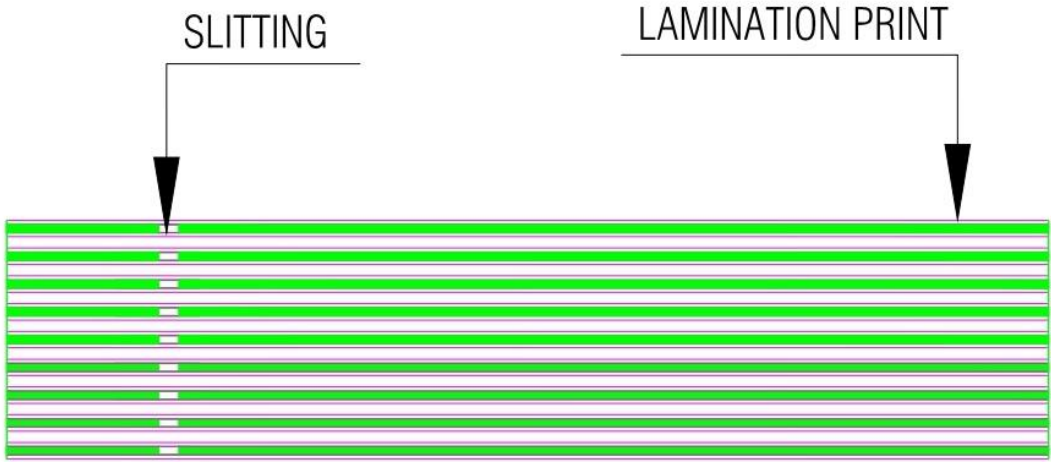

STACK THE PRINTS WITH RIGHT ANGLE

STACK THE PRINTS WITH RIGHT ANGLE

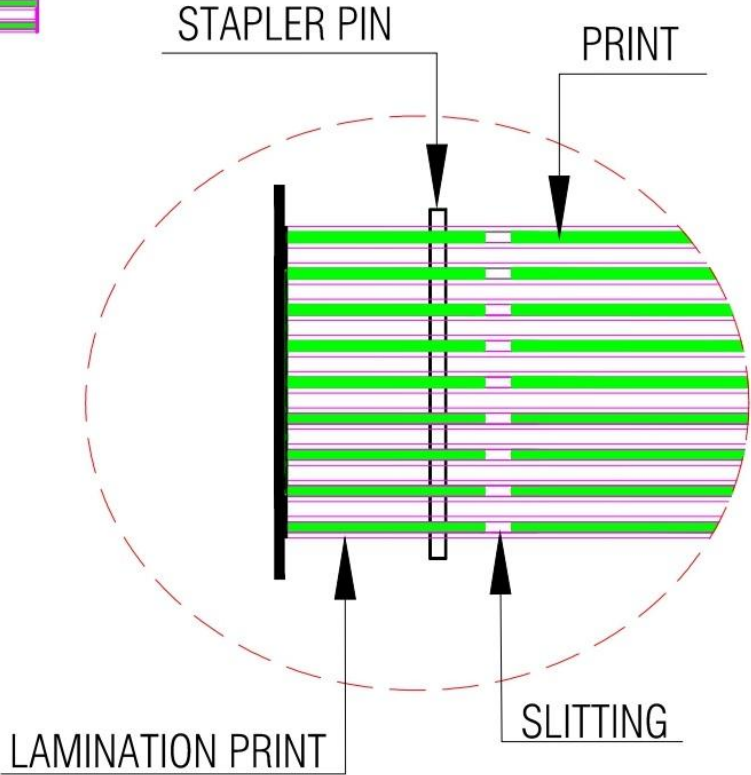
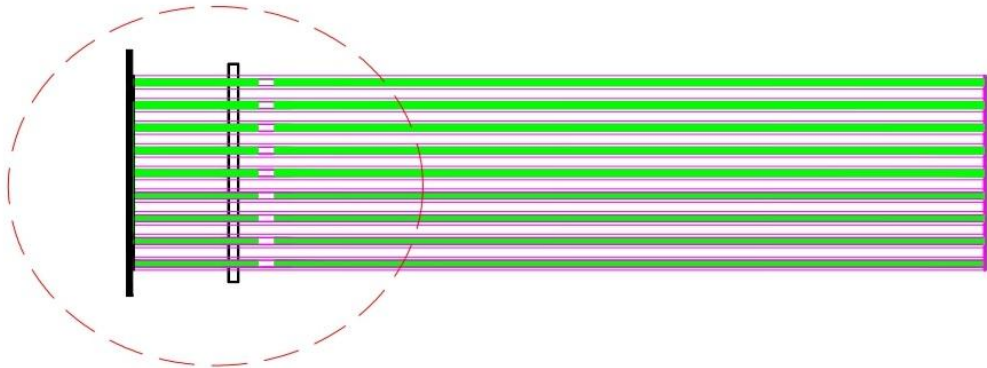

# APPLICATION IN VARIOUS INDUSTRIES

## VISUAL BOOKS :

- Architecture.
- Home Decor & Interior Design.
- Automobile.
- Food & Pharmacy.
- Fashion.
- Travelling.
- Wedding.
- Baby Albums.
- School Albums.



**Regular Binding**

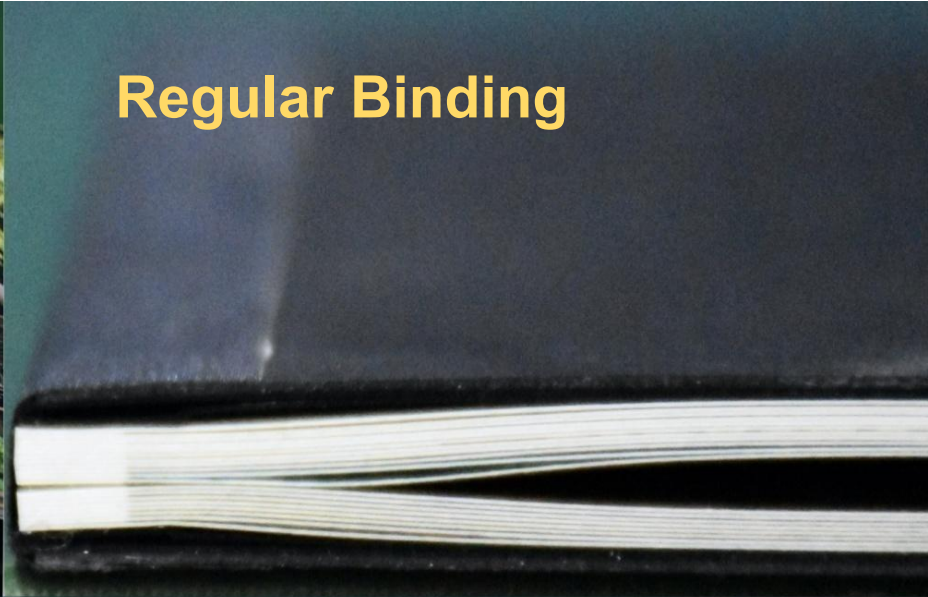

**LP13 SLa Binding**



# PIV<sup>IN</sup>ACLE<sup>®</sup>



[pinnacletechnocrats.com](http://pinnacletechnocrats.com)



[sales@pinnacletechnocrats.com](mailto:sales@pinnacletechnocrats.com)

