



Product Technical Specification

**THERMAL LAMINATION TLS 450 m**



## THERMAL LAMINATION **TLS 450 m**

# THERMAL LAMINATION TLS 450 m

## FLOOR DIMENSION

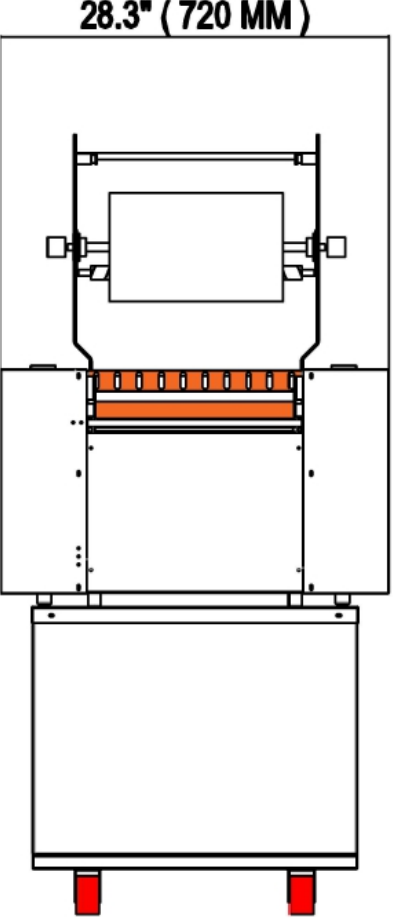
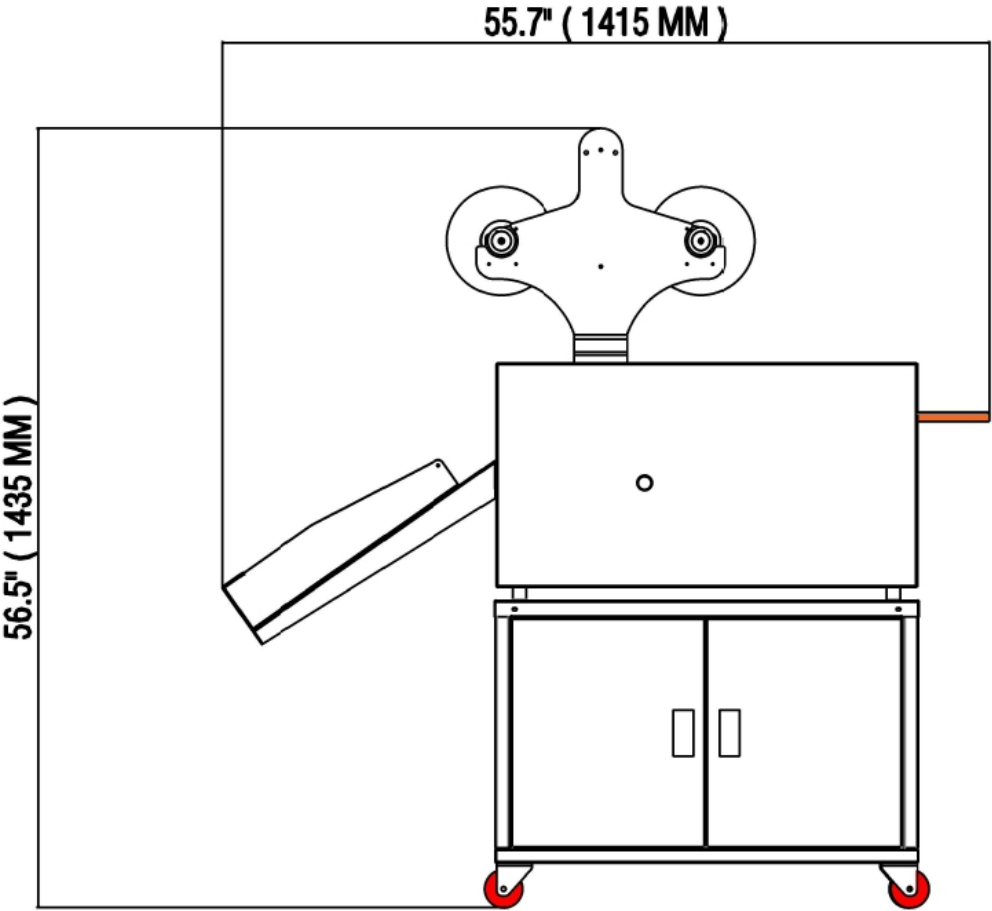



## THERMAL LAMINATION TLS 450 m with rewinding system

# THERMAL LAMINATION TLS 450 m with rewinding

## FLOOR DIMENSION

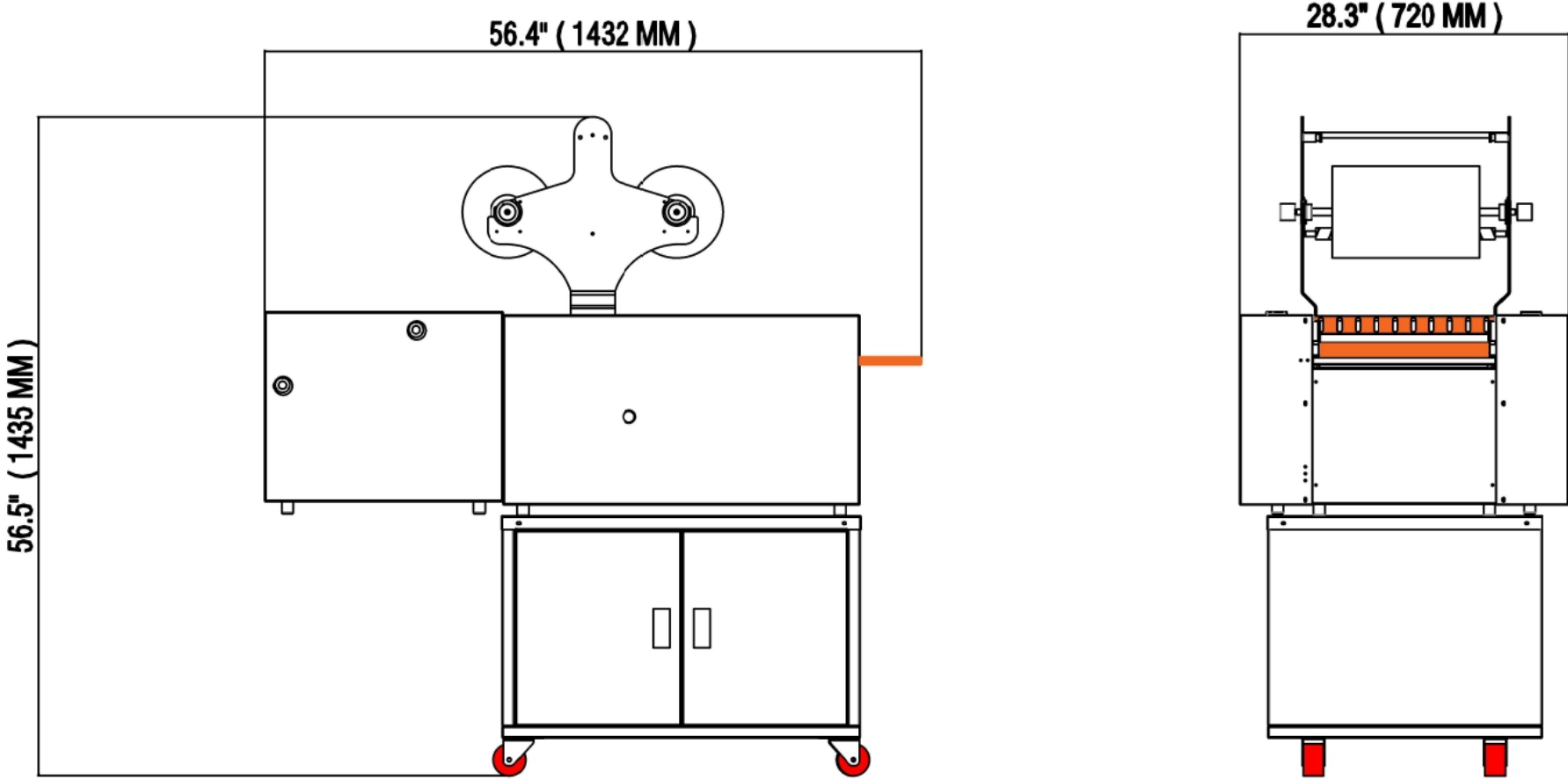

# TECHNICAL SPECIFICATION



<b>MACHINE DIMENSION</b>	<b>1415 x 720 x 1435 (mm)</b>
<b>MACHINE DIMENSION WITH REWINDING</b>	<b>1432 x 720 x 1435 (mm)</b>
<b>POWER SUPPLY</b>	<b>220V AC ( 50 Hz )</b>
<b>POWER CONSUMPTION</b>	<b>2500 WATTS</b>
<b>LAMINATION SPEED</b>	<b>UPTO 5 MTR / MIN, VARIABLE</b>
<b>MIN PAPER SIZE</b>	<b>200 mm   200 mm</b>
<b>MAX PAPER SIZE</b>	<b>330 mm   482 mm</b>
<b>THICKNESS OF PAPER</b>	<b>125 GSM – 400 GSM</b>
<b>SPEED</b>	<b>450 SHEETS / HR</b>



Thermal Lamination TLS 450 m is Pinnacle's latest model developed, especially to give an exotic and enhanced finishing to the media / prints. This is a Manual Feeding Single side lamination machine with Auto cut system also comes with Rewinding system.

# FEATURES



- User friendly LCD Control Display to operate various functions.
- High Accuracy Sensor has been provided to maintain Accurate Temperature.
- Anti Curl Device.
- Easily controlled speed for varied papers and lamination films, speed up to 5 Mtr /min.
- 1”(Inch) core for small lamination film roll & 3”(Inch) core for jumbo Film roll.
- Inline Trimming and Perforation
- Standby mode to save the power consumption on idle condition of the machine.





[pinnacletechnocrats.com](http://pinnacletechnocrats.com)



[sales@pinnacletechnocrats.com](mailto:sales@pinnacletechnocrats.com)

